

**Legend**

- Site Boundary
- Turbines
- Solar PV Modules
- Inverter
- Substation
- Construction Compound
- Battery Site
- Borrow Pit Location
- Borrow Pit Micrositing Allowance
- Turbine Hardstanding Concrete
- Access Track, Junction & Turning Heads

|                                       |             |
|---------------------------------------|-------------|
| Figure Title                          |             |
| <b>Site Layout</b>                    |             |
| Project Name                          |             |
| <b>M74 West Renewable Energy Park</b> |             |
| Project Number                        | Figure No.  |
| 1620015684                            | 2.1         |
| Date                                  | Prepared By |
| August 2024                           | BE          |
| Scale                                 | Issue       |
| 1:20,000 @A3                          | 1           |
| Client                                |             |
| <b>M74 West Ltd</b>                   |             |





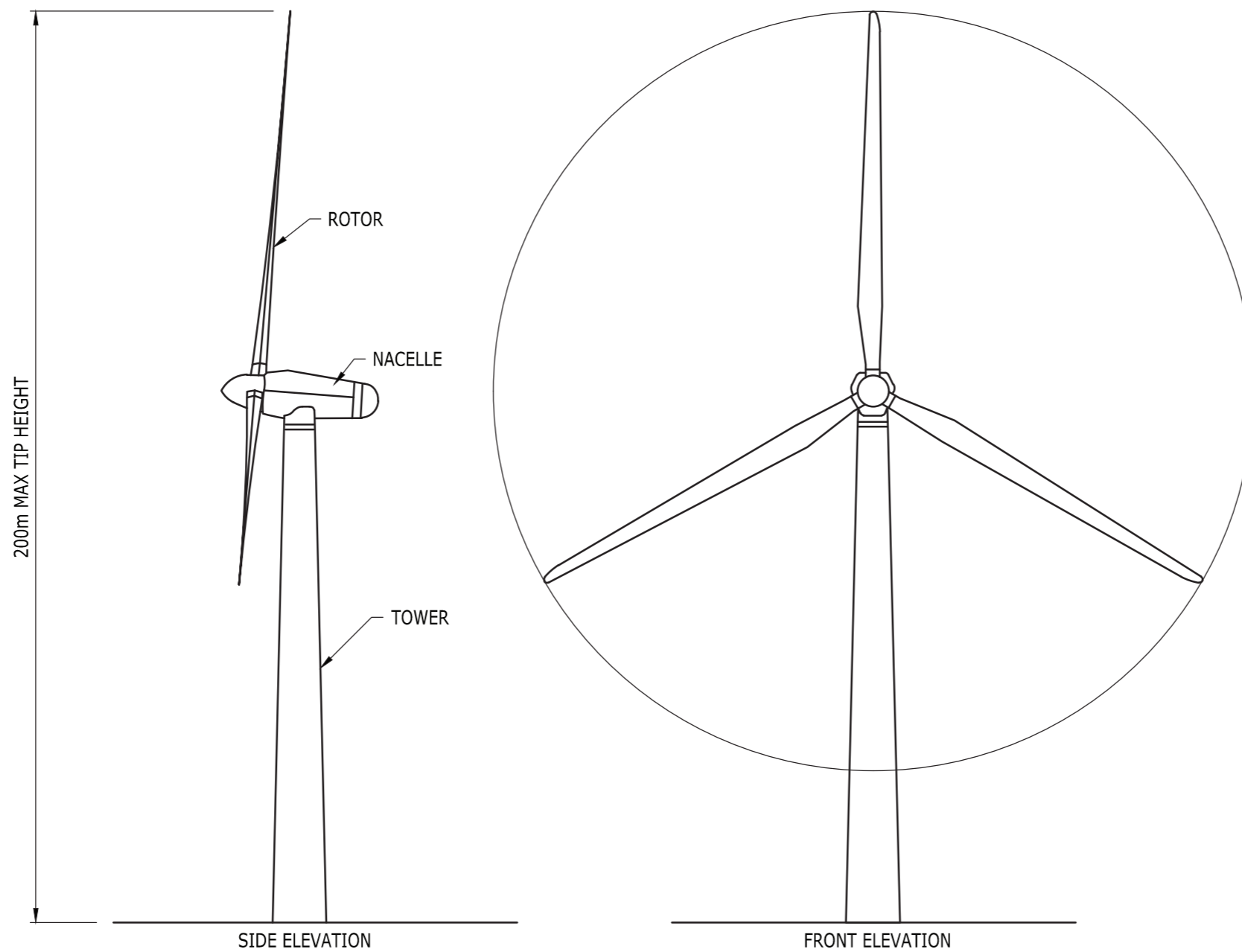

**TYPICAL WIND TURBINE GENERATOR ELEVATIONS**  
**NOT TO SCALE**

|  |                   |               |
|--|-------------------|---------------|
| Figure Title<br><b>Figure 2.2: Typical Wind Turbine Elevations</b> |                   |               |
| Project Name<br><b>M74 West Renewable Energy Park</b>              |                   |               |
| Project No./Filey ID<br>1620015684 / REH2023N01765                 |                   |               |
| Date<br>May 2024   | Figure No.<br>2.2 | Version<br>01 |
| Scale<br>NOT TO SCALE  | Prepared by<br>SR |               |
| Client<br><b>M74 West Ltd</b>                                      |                   |               |



**NOTES:**

1. ALL DIMENSIONS ARE IN METRES UNLESS NOTED OTHERWISE.

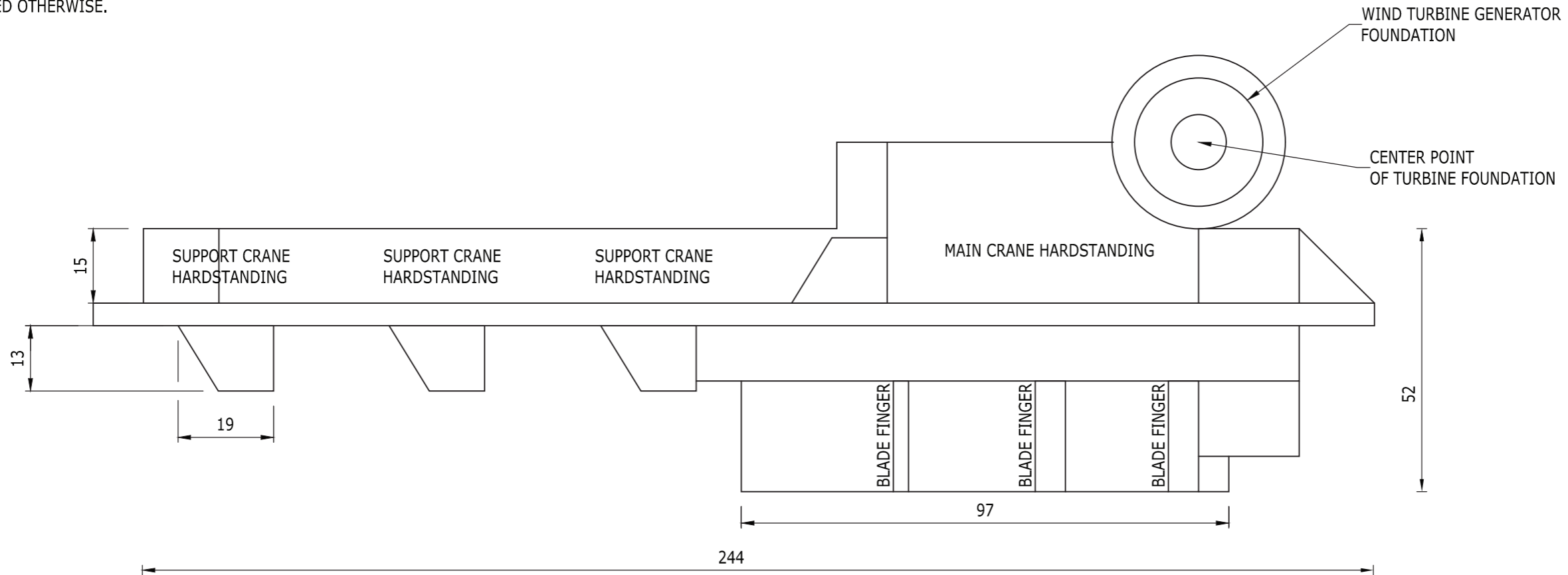

**CRANE HARDSTANDING LAYOUT  
(NOT TO SCALE)**

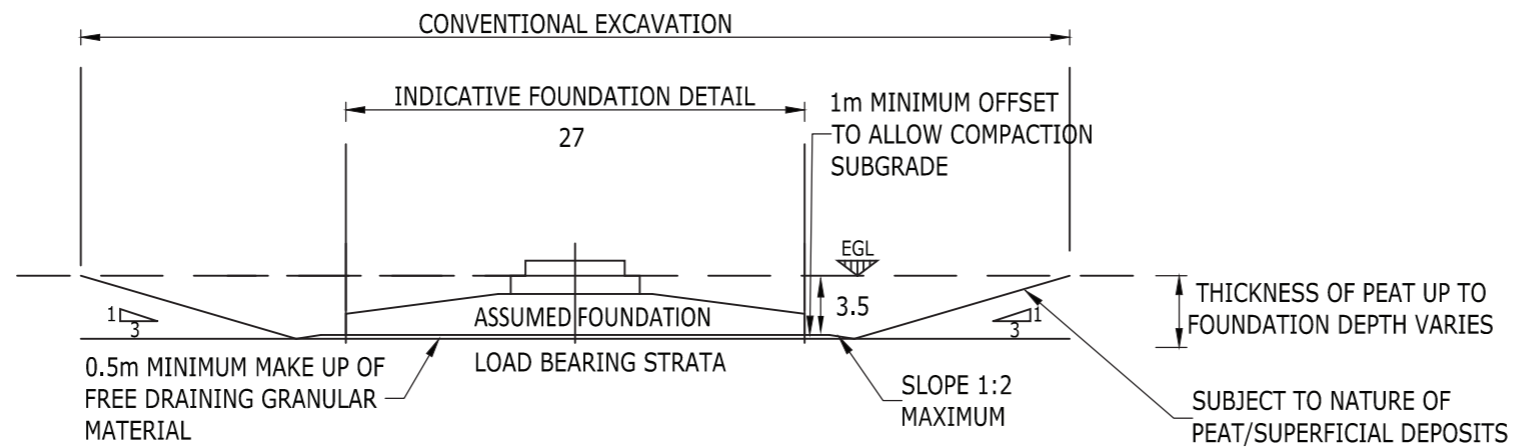

**TURBINE FOUNDATION DETAIL  
(NOT TO SCALE)**

Figure Title  
Figure 2.3: Typical Turbine Foundations & Crane Hardstanding

Project Name  
M74 West Renewable Energy Park

Project No./Filey ID  
1620015684 / REH2023N01765

|                     |                   |               |
|---------------------|-------------------|---------------|
| Date<br>August 2024 | Figure No.<br>2.3 | Version<br>02 |
|---------------------|-------------------|---------------|

|                       |                      |
|-----------------------|----------------------|
| Scale<br>NOT TO SCALE | Prepared by<br>SR/GP |
|-----------------------|----------------------|

Client  
**M74 West Ltd**



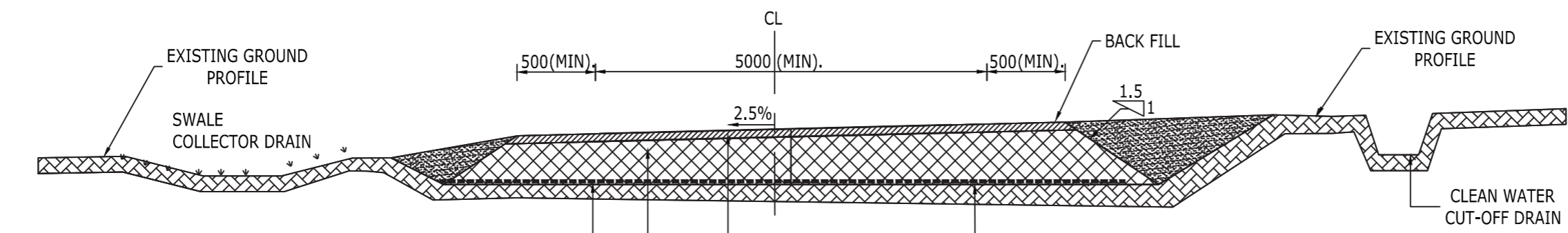

LAYER 1 : GEOTEXTILE WITH PROPERTIES IN ACCORDANCE WITH THE CIVIL SPECIFICATION

LAYER 2 : 500mm MIN. CLASS 6F2 FILL MATERIAL IN ACCORDANCE WITH CLAUSE 613 OF VOLUME 1 OF THE SPECIFICATION FOR HIGHWAY WORKS

LAYER 3\* : 100mm MIN. IMPORTED TYPE 1 CLAUSE 803 MATERIAL IN ACCORDANCE WITH VOLUME 1 SPECIFICATION FOR HIGHWAY WORKS SERIES 800

\*IF SUITABLE MATERIAL IS AVAILABLE ON SITE THE RUNNING SURFACE MAY ALSO BE TAKEN FROM ONSITE BORROW PITS.

SUITABLE FORMATION LEVEL TO BE AGREED WITH THE ENGINEER ON SITE

Figure Title  
**Figure 2.4: Typical Access Track Detail**

Project Name  
**M74 West Renewable Energy Park**

Project No./File ID  
 1620015684 / REH2023N01765

|                     |                   |               |
|---------------------|-------------------|---------------|
| Date<br>August 2024 | Figure No.<br>2.4 | Version<br>02 |
|---------------------|-------------------|---------------|

|                       |                      |
|-----------------------|----------------------|
| Scale<br>NOT TO SCALE | Prepared by<br>SR/GP |
|-----------------------|----------------------|

Client  
**M74 West Ltd**





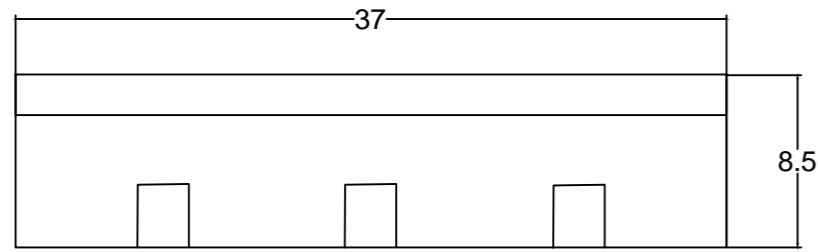

FRONT ELEVATION -  
CONTROL BUILDING

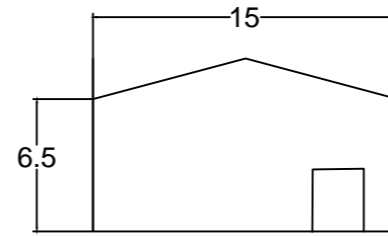

SIDE ELEVATION -  
CONTROL BUILDING

ALL  
DIMENSIONS  
IN METRES  
UNLESS  
SPECIFIED  
OTHERWISE\*\*

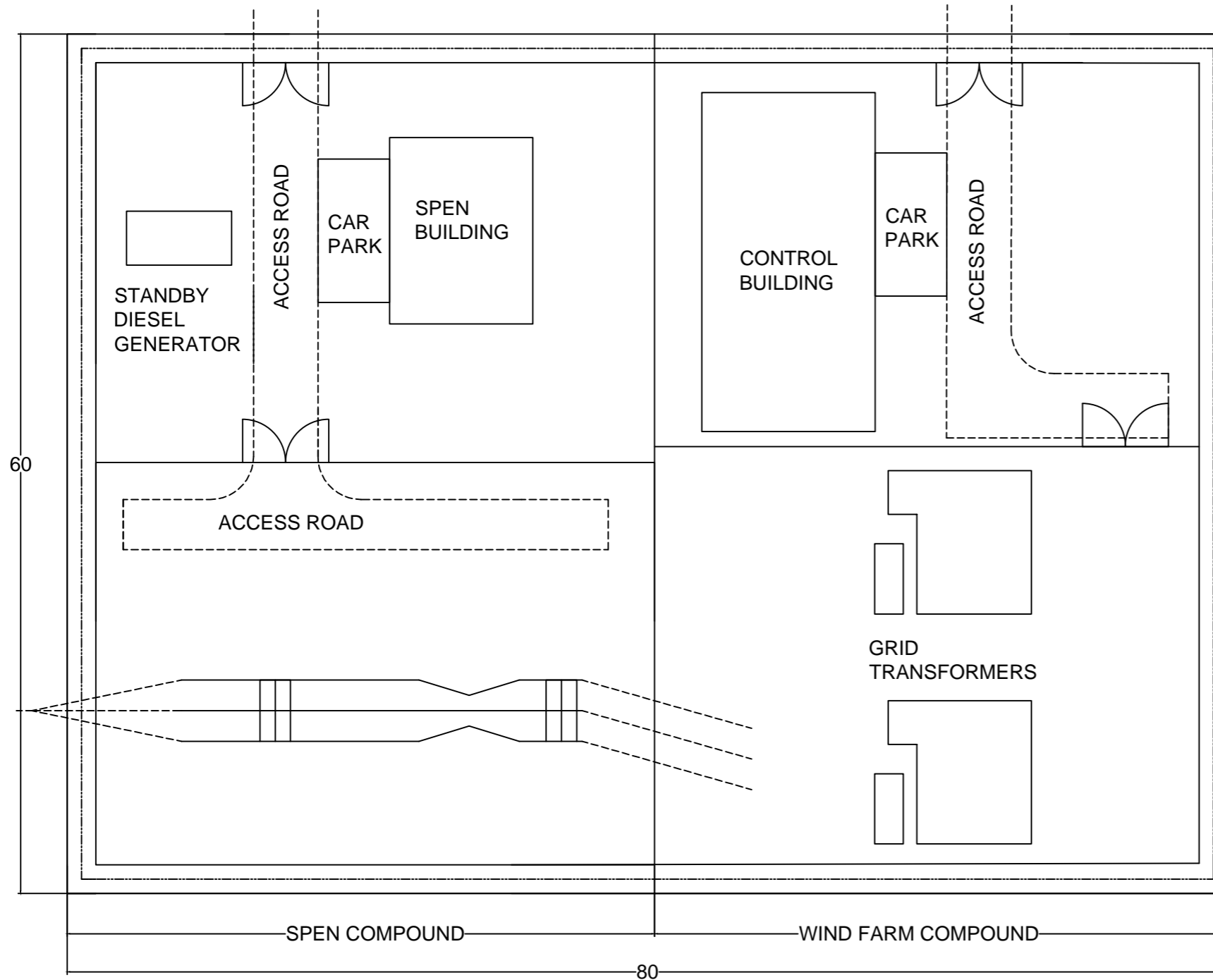

Notes

1. Layout provided is indicative only. Final arrangement shall be determined prior to construction after discussion with the SP Energy Networks (SPEN).
2. Final electrical equipment and arrangement is to be confirmed.
3. Finish and colour of the buildings shall be agreed prior to construction.
4. The control building shall house the wind farm switchgear, control and communication equipment required to operate the wind farm and site welfare facilities including toilets, office/rest room, kitchen and store room.
5. Design provided is indicative only and is to be confirmed prior to construction.

Figure Title  
**Typical Substation & Compound  
Layout**

Project Name  
**M74 West Renewable Energy  
Park**

|                                     |                          |
|-------------------------------------|--------------------------|
| Project Number<br><b>1620015684</b> | Figure No.<br><b>2.5</b> |
|-------------------------------------|--------------------------|





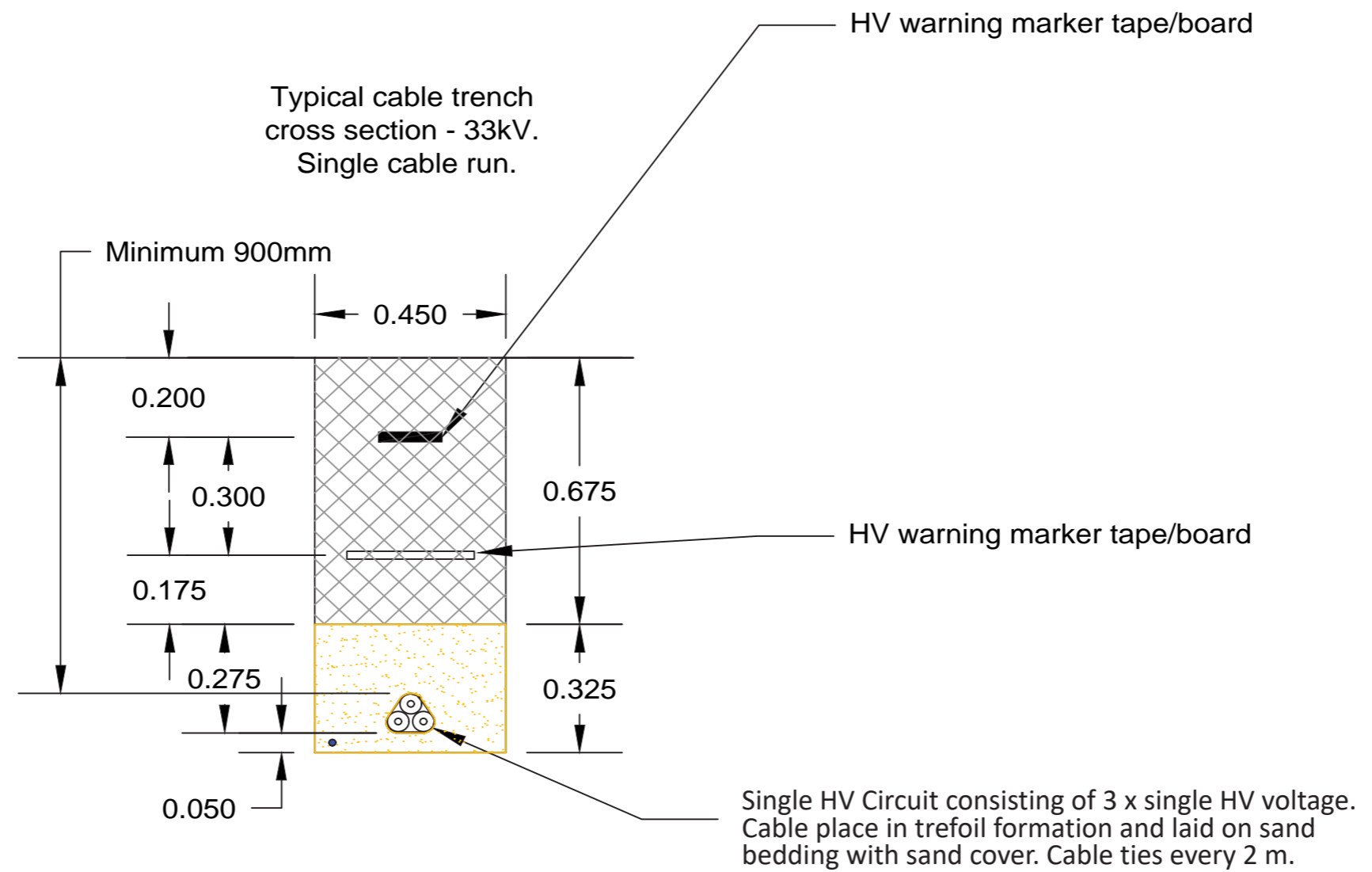

|                               |                          |
|-------------------------------|--------------------------|
| Date<br><b>September 2024</b> | Prepared By<br><b>BE</b> |
|-------------------------------|--------------------------|

|                              |                   |
|------------------------------|-------------------|
| Scale<br><b>NOT TO SCALE</b> | Issue<br><b>1</b> |
|------------------------------|-------------------|

Client  
**M74 West Ltd**





-  Backfill of Excavated Soils
-  Sand
-  Concrete
-  Earthing Cable
-  PVC 110mm Duct
-  PVC 200mm Ducts for 33kV Cabling

|   |                   |               |
|---|-------------------|---------------|
| Figure Title<br>Figure 2.6: Typical Cable Trench Section                              |                   |               |
| Project Name<br>M74 West Renewable Energy Park  |                   |               |
| Project No./Filey ID<br>1620015684 / REH2023N01765                                    |                   |               |
| Date<br>May 2024  | Figure No.<br>2.6 | Version<br>01 |
| Scale<br>NOT TO SCALE   | Prepared by<br>SR |               |
| Client<br><b>M74 West Ltd</b>   |                   |               |
|  |                   |               |



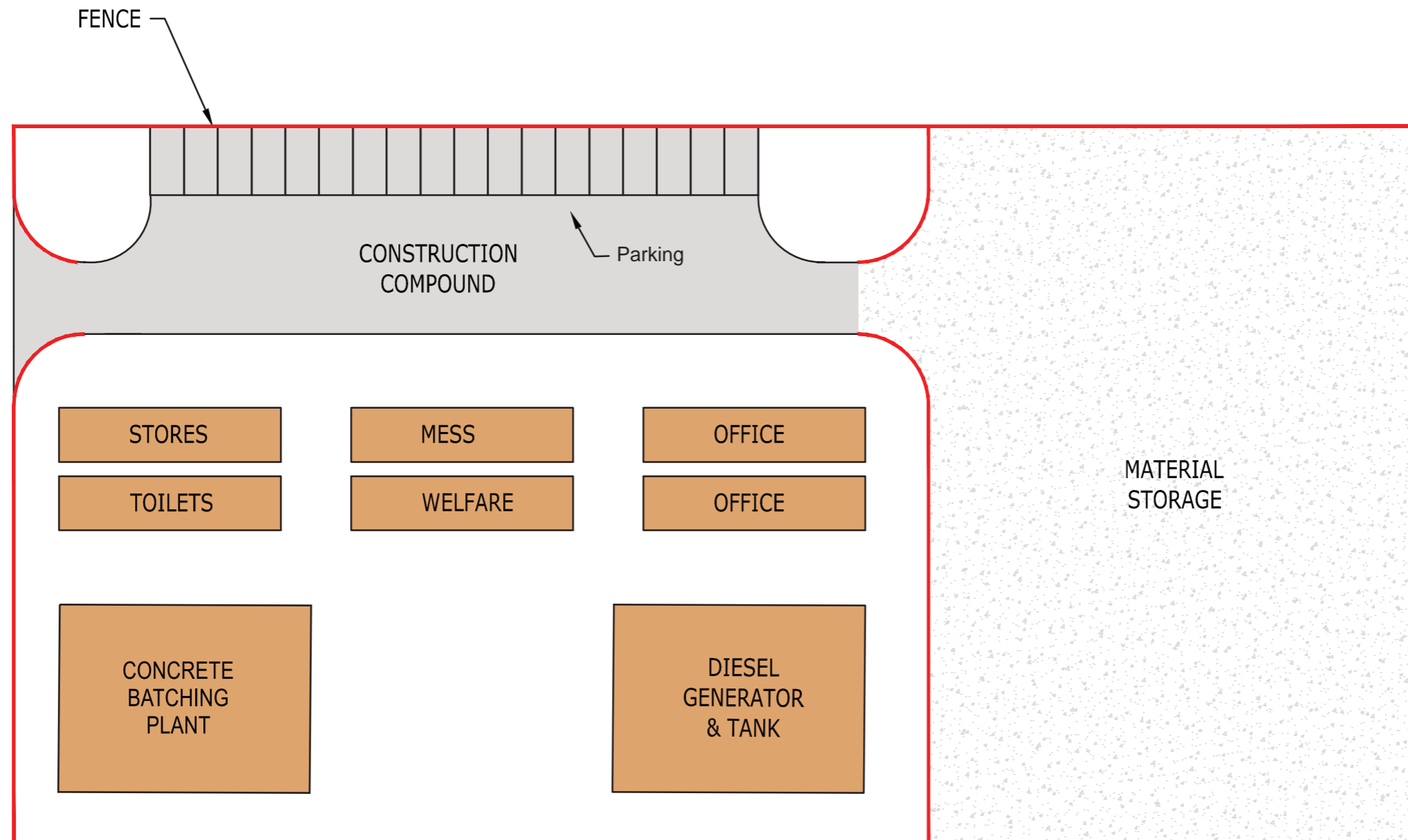

Figure Title  
 Figure 2.7: Typical Temporary Construction Compound Layout

Project Name  
 M74 West Renewable Energy Park

Project No./Filey ID  
 1620015684 / REH2023N01765

|                     |                   |               |
|---------------------|-------------------|---------------|
| Date<br>August 2024 | Figure No.<br>2.7 | Version<br>02 |
|---------------------|-------------------|---------------|

|                       |                      |
|-----------------------|----------------------|
| Scale<br>NOT TO SCALE | Prepared by<br>SR/GP |
|-----------------------|----------------------|

Client  
**M74 West Ltd**





- Legend**
- Site Boundary
  - Security Fence
  - Substation Area
  - Fire Management Area
  - Spares Container
  - Fire Hydrant
  - Parking
  - BESS Area
  - CCTV & Lighting
  - Buried Firewater Storage Tank
  - PCS Unit
  - BESS Container
  - Infrastructure Road
  - Site Track

**Notes**

**BESS**  
50MWac  
44no. of BESS Containers

**PCS**  
11 PCS Units  
PCS consists of 2no. of Inverters and 1no. of Transformers

|   |                          |                      |
|---|--------------------------|----------------------|
| Figure Title<br><b>Figure 2.8: Battery Storage Layout</b> |                          |                      |
| Project Name<br><b>M74 West Renewable Energy Park</b>     |                          |                      |
| Project No./Filey ID<br><b>1620015684 / REH2023N01765</b> |                          |                      |
| Date<br><b>August 2024</b>                                | Figure No.<br><b>2.8</b> | Version<br><b>01</b> |
| Scale<br><b>NOT TO SCALE</b>                              | Prepared by<br><b>SR</b> |                      |
| Client<br><b>M74 West Ltd</b>                             |                          |                      |





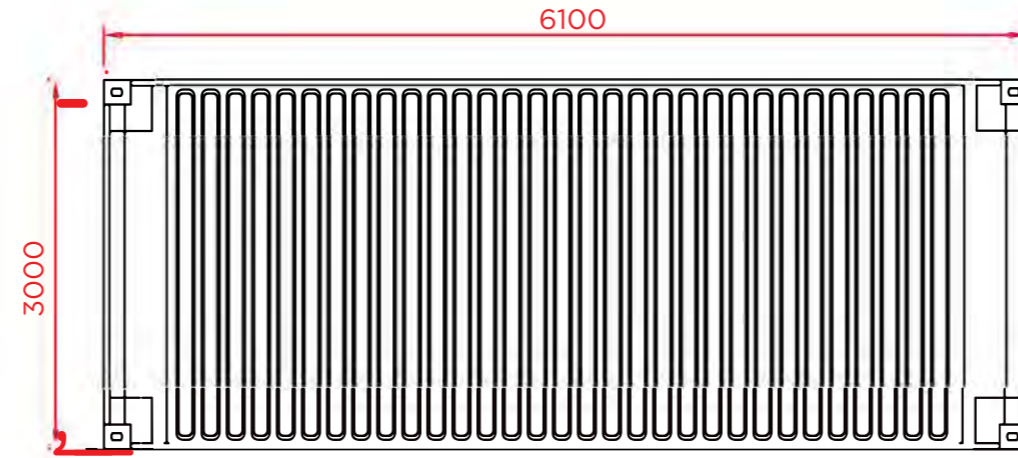

PLANVIEW

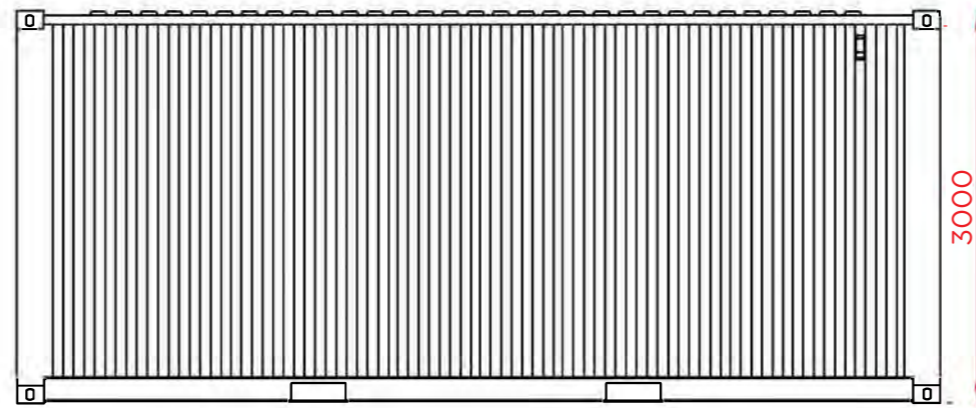

SIDE ELEVATION

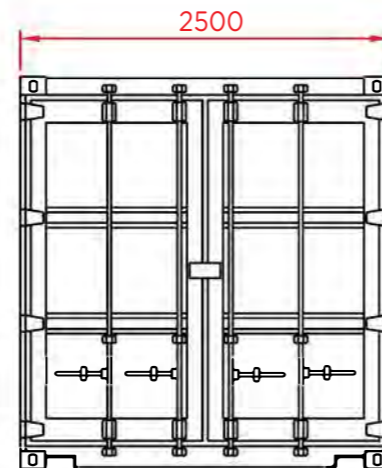

ENDELEVATION

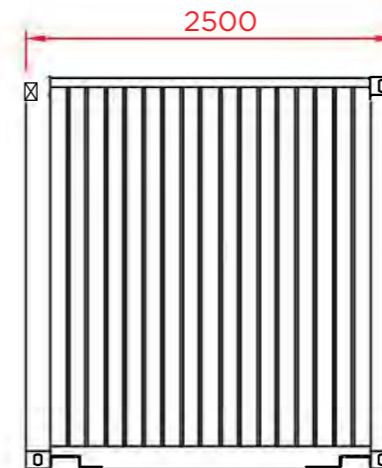

ENDELEVATION

Figure Title  
**Figure 2.9: Typical Battery Detail**

Project Name  
**M74 West Renewable Energy Park**

Project No./Filey ID  
 1620015684 / REH2023N01765

|                  |                   |               |
|------------------|-------------------|---------------|
| Date<br>May 2024 | Figure No.<br>2.9 | Version<br>01 |
|------------------|-------------------|---------------|

|                       |                   |
|-----------------------|-------------------|
| Scale<br>NOT TO SCALE | Prepared by<br>SR |
|-----------------------|-------------------|

Client  
**M74 West Ltd**



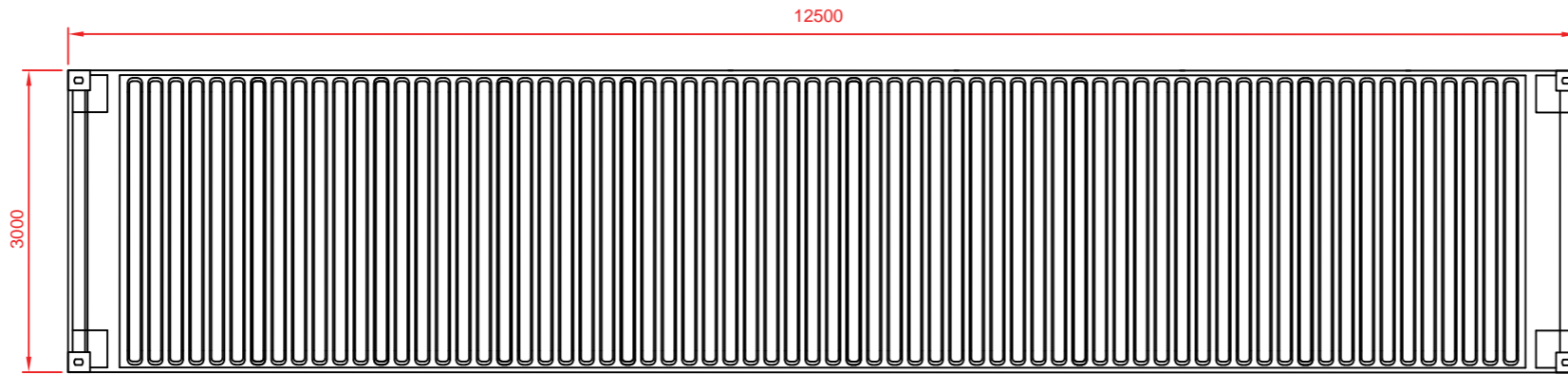

**PLAN VIEW**

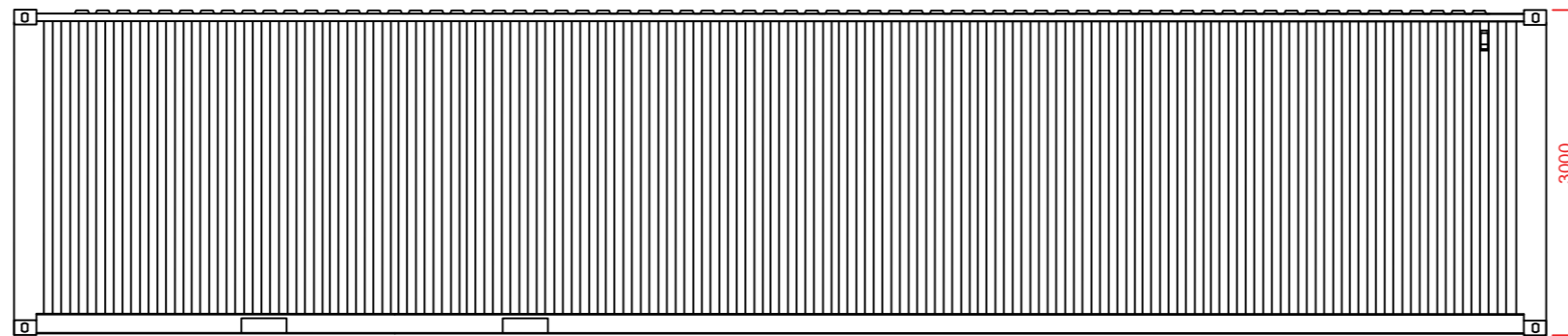

**SIDE ELEVATION**

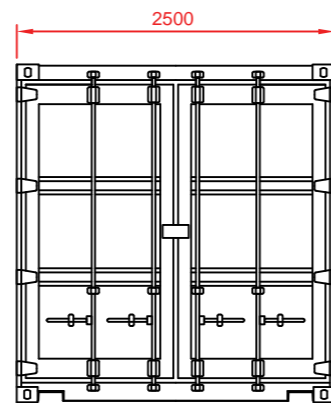

**END ELEVATION**

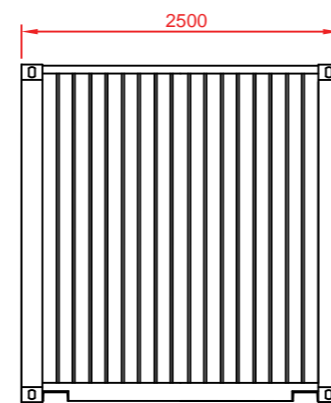

**END ELEVATION**

|  |                    |               |
|--|--------------------|---------------|
| Figure Title<br><b>Figure 2.10: Typical PCS Elevations</b> |                    |               |
| Project Name<br><b>M74 West Renewable Energy Park</b>      |                    |               |
| Project No./Filey ID<br>1620015684 / REH2023N01765         |                    |               |
| Date<br>May 2024   | Figure No.<br>2.10 | Version<br>01 |
| Scale<br>NOT TO SCALE                                      | Prepared by<br>SR  |               |
| Client<br><b>M74 West Ltd</b>                              |                    |               |
|  |                    |               |



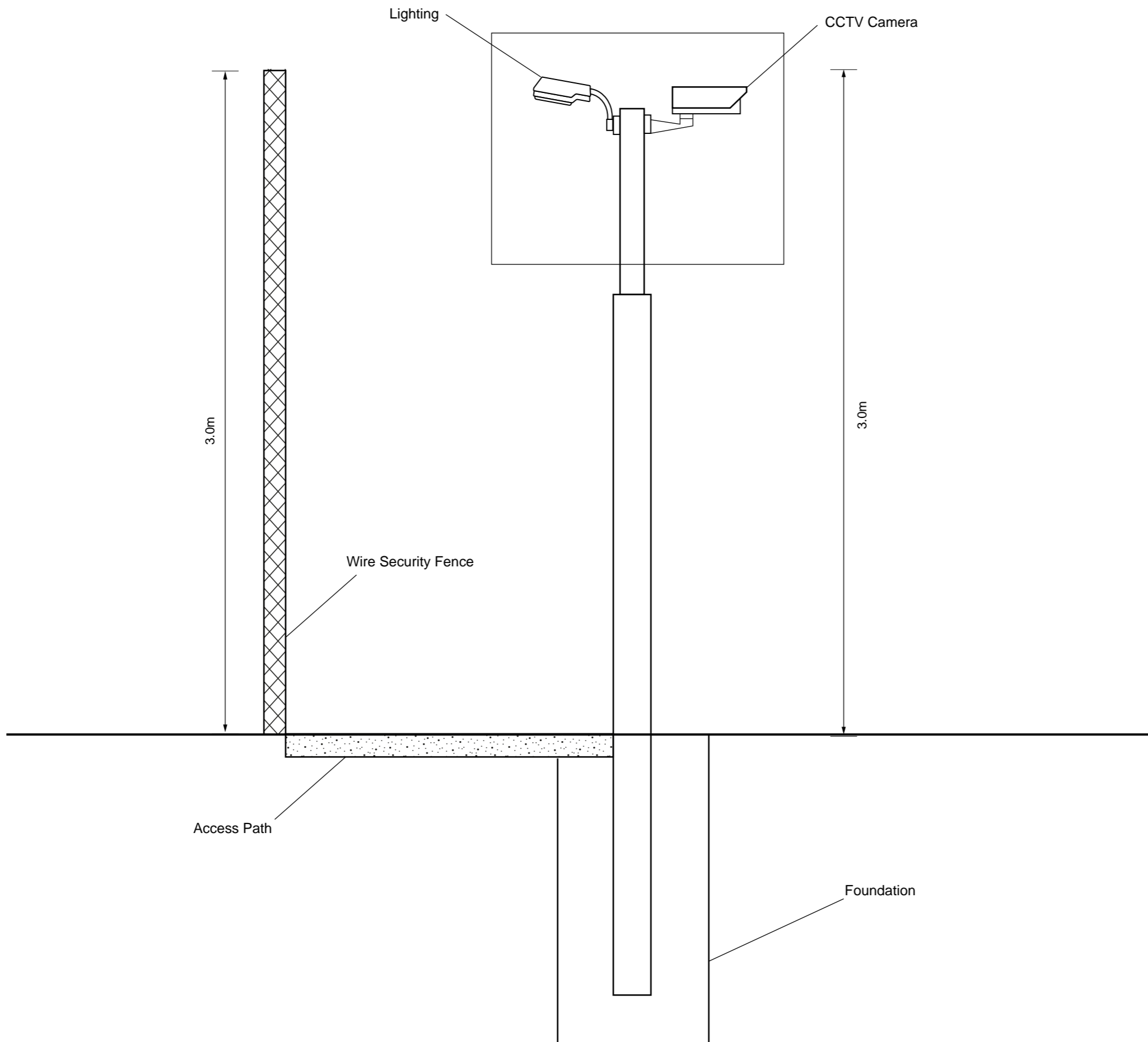

Figure Title  
**Figure 2.11: Typical CCTV & Fencing Layout**

Project Name  
**M74 West Renewable Energy Park**

Project No./File ID  
**1620015684 / REH2023N01765**

|                  |                    |               |
|------------------|--------------------|---------------|
| Date<br>May 2024 | Figure No.<br>2.11 | Version<br>01 |
|------------------|--------------------|---------------|

|                       |                   |
|-----------------------|-------------------|
| Scale<br>NOT TO SCALE | Prepared by<br>SR |
|-----------------------|-------------------|

Client  
**M74 West Ltd**



### Structure Front View

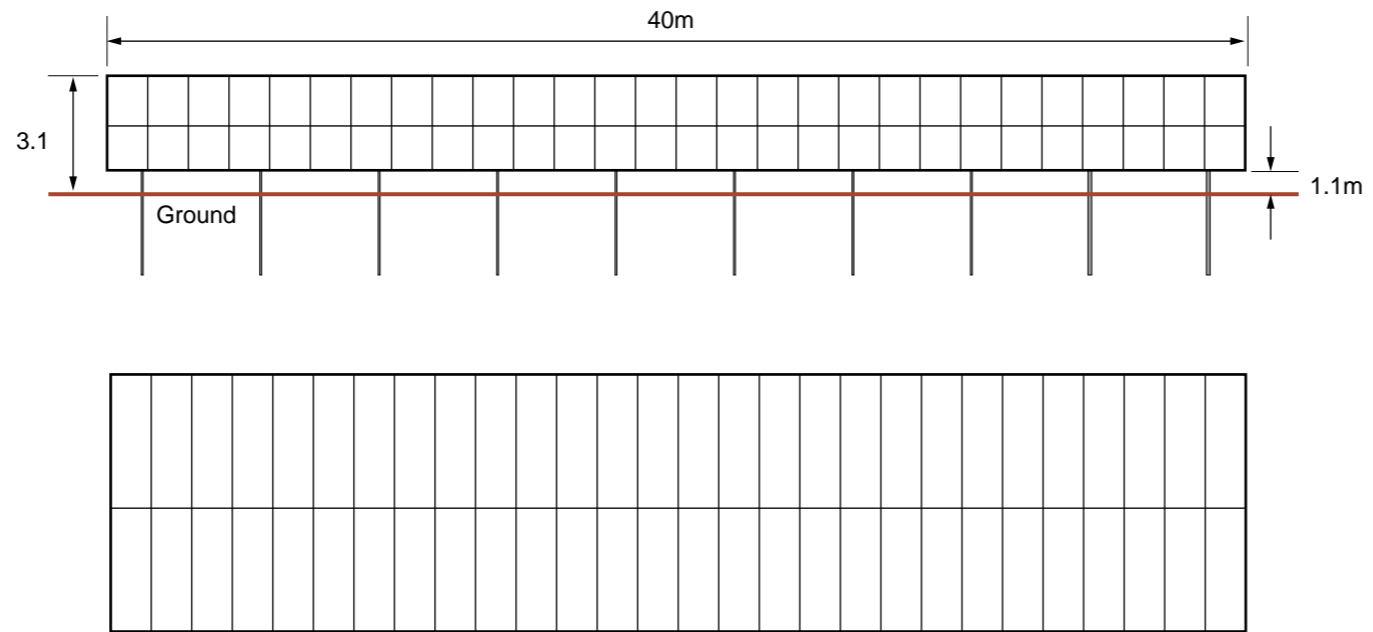

### Table Post Type

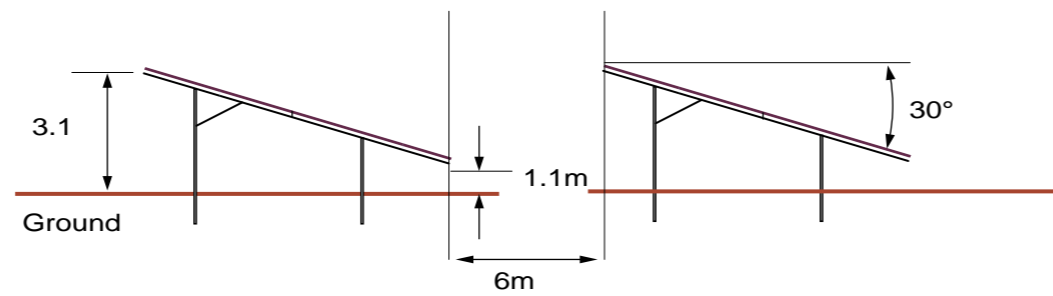

### Concrete Base Type

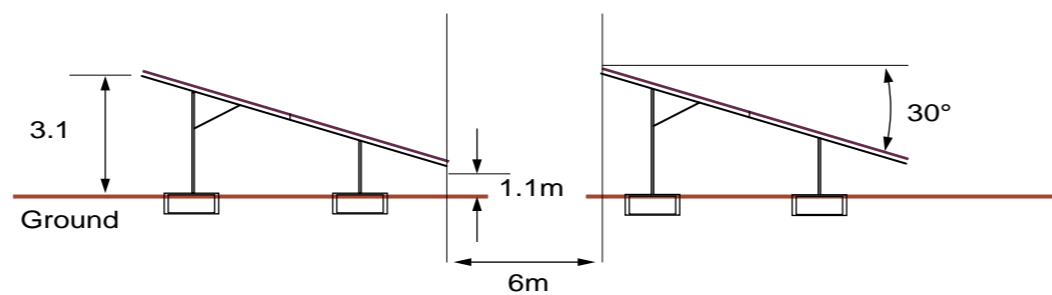

Figure Title  
Figure 2.12: Typical Solar PV Equipment & Materials Detail

Project Name  
M74 West Renewable Energy Park

Project No./Filey ID  
1620015684 / REH2023N01765

|                  |                    |               |
|------------------|--------------------|---------------|
| Date<br>May 2024 | Figure No.<br>2.12 | Version<br>01 |
|------------------|--------------------|---------------|

|                       |                   |
|-----------------------|-------------------|
| Scale<br>NOT TO SCALE | Prepared by<br>SR |
|-----------------------|-------------------|

Client  
**M74 West Ltd**

